

TECHNICAL DATA SHEET LED NGP



LED-NGP-21 X-RAY FILM VIEWER

HOW DOES THE X-RAY FILM VIEWER WORK?

LED-NGP X-ray film viewers are medical devices designed for the analysis of medical images on X-ray films, which is one of the basic methods of diagnosing human diseases. X-ray film viewers manufactured in LED technology have extremely efficient parameters, such as the value of luminance intensity, uniformity of screen luminance, low operating cost- long lifetime, and low energy consumption. The devices do not come into contact with patients as they are devices supporting the process of analyzing X-rays by a doctor. The products are made in the 1st class of protection against electric shock. They can be used in operating theaters, doctor's offices, X-ray laboratories, etc.

***Optional:**
table top stand for additional fee

BASIC DATA:

Mounting type	wall-mounted*
Casing material	powder-coated steel sheet
Viewer screen material	PMMA
Switch on/off	built-in x-ray film viewer body (Fig. 1 point 1)
Automatic clip for X-ray film	yes
Ambient temperature	+10°C to +40°C
Relative humidity	30% to 70%
Atmospheric pressure	700 hPa to 1060 hPa
Declaration of conformity	yes
User's manual English version	yes



„Knob” for a smooth luminance adjustment with ON/OFF screen backlight

TECHNICAL DATA SHEET

LED NGP

LED-NGP-21

X-RAY FILM VIEWER

TECHNICAL DATA:

Supply voltage	90-260 V, 50-60 Hz
Power consumption	125 W
Luminance	600-6000 cd/m ² +/- 15 % (19 000 lux)
Light uniformity	≥95 %
Step-less luminance adjustment (each frame separately)	10 - 100 %
Colour temperature of the light of the lamps	> 6500 °K
Lifetime span	50 000 working hours (average 25 years)
Absolutely no light flickering	yes
Screen dimensions (L x H)	72 x 43 cm
Overall dimensions (L x W x H)	795 x 35 (+15 knob) x 520 mm
Total mass	8.0 kg
Class of protection against electric shock	I
Ingress Protection Code	IP 20
Class for the medical environment	B - home
Group according to PN-EN 55011 Clause 5	1
Power cord length	2.5 m, ended with the socket plug

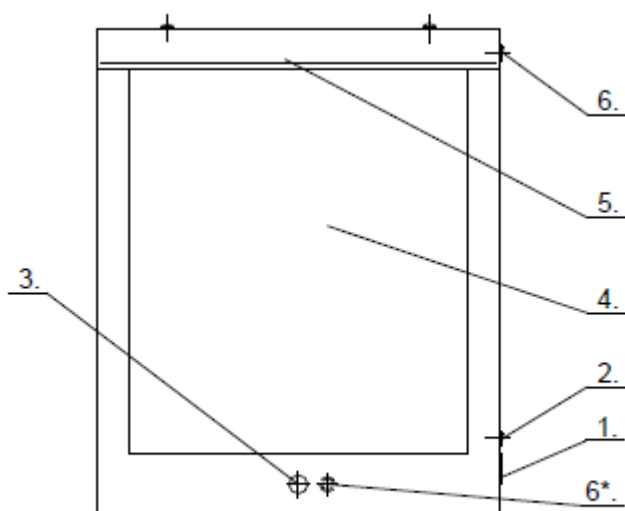

1. – connection unit with fuses
2. – main switch
3. – luminance adjustment knob with a switch off/ on
4. – screen
5. – film holder
6. – switch off the "glare"
- 6*. – for LED-NGP 31 and LED-NGP 41 X-ray viewers switch off the "glare" is near the luminance adjustment knob on the front panel

Fig.1. X – Ray film viewer LED-NGP-11